

### FEATURES

- Long life, 105°C, 4,000 ~ 10,000 hours assured
- Low Impedance, suitable for switching power supplies
- Smaller size with large permissible ripple current

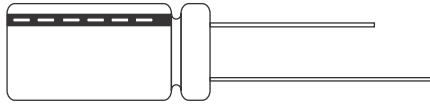

### SPECIFICATIONS

Items	Performance										
Life	at 105 °C 4,000 ~ 10,000 Hours										
Operating Temp.	-55 °C ~ +105 °C										
Capacitance Tolerance	±20% (at 120Hz, 20 °C)										
Leakage Current (at 20 °C)	I = - 0.1CV or 3 (μA) whichever is greater (after 2 minutes) Where C = rated capacitance in μF. V = rated DC working voltage in V.										
Dissipation Factor (Tan φ at 120Hz, 20°C)	Rated Voltage	6.3	10	16	25	35	50	63			
	Tan φ (max)	0.22	0.19	0.16	0.14	0.12	0.10	0.09			
Low Temperature Characteristics (at 120Hz)	Impedance ratio shall not exceed the values given in the table below.										
	Rated Voltage		6	10	16	25	35	50	63		
	Impedance Ratio	Z (-25°C) / Z (+20 °C)	3	3	3	3	3	3	3	3	
Load Life Test	Test Time	6.3 ~ 10V	4,000 Hrs for D = 5 ~ 6.3mm								
			6,000 Hrs for D = 8 ~ 10mm								
	8,000 Hrs for D ≥ 12.5mm										
	16 ~ 63V	5,000 Hrs for D = 5 ~ 6.3mm									
		7,000 Hrs for D = 8 ~ 10mm									
		10,000 Hrs for D ≥ 12.5mm									
	Capacitance Change	Within ± 25% of initial value									
	Dissipation Factor	Less than 200% of specified value									
Leakage Current	Within specified value										
* The above specifications shall be satisfied when the capacitors are restored to 20 °C after the rated voltage applied with rated ripple current for 4,000 ~ 10,000hrs at 105 °C.											
Shelf Life Test	Test Time	1,000 hours									
	Capacitance Change	Within ± 25% of initial value									
	Dissipation Factor	Less than 200% of specified value									
	Leakage Current	Within specified value									
* The above specifications shall be satisfied when the capacitors are restored to 20 °C after exposing them for 1,000 hrs at 105 °C without voltage applied. The rated voltage shall be applied to the capacitors before the measurements. (Refer to JIS C 5101-4 4.1).											
Ripple Current & Frequency Multipliers	Freq. (Hz)	Cap. (μF)	120	1k	10k	100k up					
			under ~ 33	0.42	0.70	0.90	1.0				
	39 ~ 270	0.50	0.73	0.92	1.0						
	330 ~ 680	0.55	0.77	0.94	1.0						
	820 ~ 1,800	0.60	0.80	0.96	1.0						
	2,200 ~ 18,000	0.70	0.85	0.98	1.0						
Other Standards	JIS C 5101-4										

### DIMENSIONS

Unit: mm

φD	5	6.3	8	10	12.5	16	18
P	2.0	2.5	3.5	5.0	5.0	7.5	7.5
φd	0.5		0.6		0.8		
	1.0		L < 20: 1.5, L ≥ 20: 2.0				
	0.5						

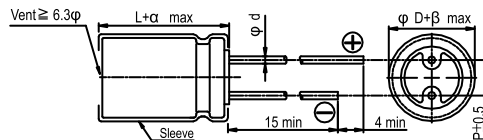

The case size of 12.5×16, 16×16, 16×20, 18×16, 18×20 and 18×25 are suitable for below diagram:

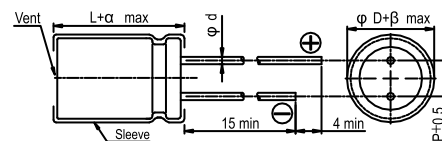



**DIMENSIONS & PERMISSIBLE RIPPLE CURRENT AND MAX IMPEDANCE**

Dimension:  $\phi D \times L$ (mm)  
Ripple Current: mA/rms at 100Hz, 105°C

Code	V. DC $\mu F$	35V (1V)				50V (1H)				63V (1J)			
		$\phi D \times L$	Impedance ( $\Omega$ , Max / 100kHz)		Ripple Current (mA / rms, 105°C) 100k Hz	$\phi D \times L$	Impedance ( $\Omega$ , Max / 100kHz)		Ripple Current (mA / rms, 105°C) 100k Hz	$\phi D \times L$	Impedance ( $\Omega$ , Max / 100kHz)		Ripple Current (mA / rms, 105°C) 100k Hz
			20°C	-10°C			20°C	-10°C			20°C	-10°C	
2.2	2R2				5 x 11	3.3	6.6	43					
3.3	3R3				5 x 11	2.9	5.8	53					
4.7	4R7				5 x 11	2.5	5.0	95					
10	100				5 x 11	2	4.0	130					
15	150								5 x 11	1.2	2.4	165	
22	220				5 x 11	0.91	1.82	180					
33	330	5 x 11	0.58	1.16	210				6.3 x 11	0.49	0.98	265	
56	560	6.3 x 11	0.22	0.44	340	6.3 x 11	0.39	0.78	295	8 x 11.5	0.31	0.62	500
82	820								8 x 15	0.22	0.44	665	
									10 x 12.5	0.150	0.3	690	
100	101					8 x 11.5	0.220	0.440	555				
120	121					8 x 15	0.150	0.300	730	8 x 20.0	0.170	0.340	820
										10 x 16.0	0.110	0.220	950
150	151	8 x 11.5	0.110	0.220	640	10 x 12.5	0.160	0.320	760				
180	181					8 x 20	0.118	0.236	910	10 x 20.0	0.078	0.156	1,150
										12.5 x 16.0	0.101	0.202	1,150
220	221	8 x 15	0.083	0.166	840	10 x 16	0.110	0.220	1,050	10 x 25	0.064	0.128	1,350
		10 x 12.5	0.080	0.160	865								
270	271	8 x 20	0.064	0.128	1,050	10.0 x 20	0.078	0.156	1,220	12.5 x 20	0.057	0.114	1,500
						12.5 x 60	0.079	0.158	1,260				
330	331	10 x 16	0.060	0.120	1,210	10 x 25	0.072	0.144	1,440				
390	391									12.5 x 20	0.057	0.114	1,500
470	471	10 x 20	0.046	0.092	1,400	10 x 30	0.056	0.112	1,690	12.5 x 30	0.039	0.078	2,300
		12.5 x 16	0.049	0.098	1,450	12.5 x 20	0.059	0.118	1,660	16 x 20	0.04	0.090	2,000
						16 x 16	0.072	0.144	1,690				
560	561	10 x 25	0.042	0.084	1,650	12.5 x 25	0.044	0.088	1,950	12.5 x 35	0.034	0.068	2,500
						18 x 16	0.070	0.140	1,930				
680	681	10 x 25	0.030	0.060	2,200					12.5 x 40	0.029	0.058	2,800
		10 x 30	0.031	0.062	2,200					16 x 25	0.035	0.070	2,600
		12.5 x 20	0.035	0.070	1,900	12.5 x 30	0.039	0.078	2,310	18 x 20	0.042	0.084	2,500
		16 x 16	0.042	0.084	1,940								
820	821	10 x 25	0.03	0.060	2,200	12.5 x 35	0.033	0.066	2,510	16 x 31.5	0.029	0.058	2,850
						16 x 20	0.044	0.088	2,210	18 x 25	0.034	0.068	2,800
1,000	102	12.5 x 25	0.027	0.054	2,230	12.5 x 40	0.027	0.054	2,920				
		18 x 16	0.043	0.086	2,210	16 x 25	0.033	0.066	2,555	16 x 35.5	0.027	0.054	2,900
						18 x 20	0.047	0.094	2,490				
1,200	122	12.5 x 30	0.024	0.048	2,650	16 x 31.5	0.027	0.054	3,010	16 x 40	0.025	0.050	3,400
		16 x 20	0.027	0.054	2,530	18 x 25	0.028	0.056	2,740	18 x 31.5	0.028	0.056	3,300
1,500	152	12.5 x 35	0.02	0.040	2,880	16 x 35.5	0.024	0.048	3,150	18 x 35.5	0.025	0.050	3,400
		12.5 x 40	0.017	0.034	3,350	16 x 40	0.021	0.042	3,710				
1,800	182	16 x 25	0.021	0.042	2,930	18 x 31.5	0.024	0.048	3,635	18 x 40	0.024	0.048	3,500
		18 x 20	0.026	0.052	2,860								
2,200	222	16 x 31.5	0.017	0.034	3,450	18 x 35.5	0.022	0.044	3,680				
		18 x 25	0.019	0.038	3,140								
2,700	272	16 x 35.5	0.015	0.030	3,610								
		18 x 31.5	0.015	0.030	4,170	18 x 40	0.018	0.036	3,800				
3,300	332	16 x 40	0.013	0.026	4,080								
		18 x 35.5	0.014	0.028	4,220								
3,900	392	18 x 40	0.012	0.024	4,280								

■ **HOW TO MAKE A PART NUMBER (Example below)**

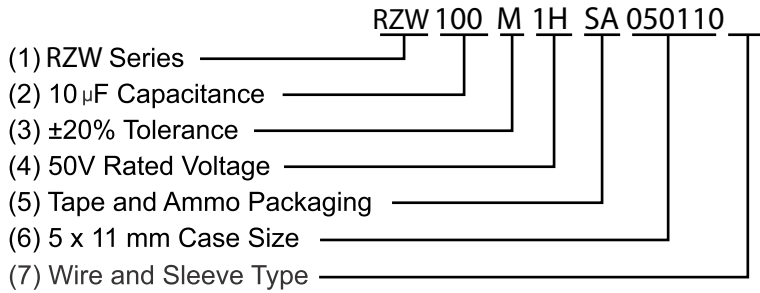

1. Series: RZW

2. Capacitance: Rated capacitance in  $\mu\text{F}$  is represented by a three digit number. The first two digits are the significant figures of the nominal capacitance and the third digit indicates the number of zeros following these figures. The decimal point is represented by the capital letter R. Please refer to the following example.

$\mu\text{F}$	0.1	0.47	1	4.7	10	47	100	470	1000	4700	10000
Part Number	0R1	R47	010	4R7	100	470	101	471	102	472	103

3. Tolerance: (20% IS Typical)

Code	K	M	T	W
Tolerance	$\pm 10\%$	$\pm 20\%$	$\pm 50\% / -10\%$	$\pm 100\% / -10\%$

4. Rated Voltage: Voltage in volts (V) is represented by a two digit code showing the rated working voltage indicated as follows:

Voltage (WV)	6.3	10	16	25	35	40	50	63	80	100	160	200	250	350	400	450
Code	0J	1A	1C	1E	1V	1G	1H	1J	1K	2A	2C	2D	2E	2V	2G	2W

5. Lead Forming & Package

Code	Lead Description	Packaging
BC	Bending Cut	Bulk Packing
BK	Straight Lead	Bulk Packing
CC	Lead Cutting	Bulk Packing
FC	Lead Forming & Cutting	Bulk Packing
FF	Lead Forming	Bulk Packing
SC	Snap-in & Cutting	Bulk Packing
SD	Cathode Lead Beading	Bulk Packing
SF	Snap-in, Forming & Cutting	Bulk Packing
SA	Straight Lead	Tape & Ammo
TA	Lead Forming	Tape & Ammo
SR	Straight Lead	Tape & Reel
TR	Lead Forming	Tape & Reel

6. Can Size

Diameter (mm)x10 & Length (mm)x10. Can Size 063110, represents 6.3mm diameter by 11mm length.

7. Sleeve Type\* = (Omit) PVC Sleeve

P = PET Sleeve

\*Note: All standard RFE Aluminum Electrolytic Capacitors are Lead (Pb) free and RoHS compliant. PET sleeve is available for those companies that also require PVC free product.

**LEADED TAPING & PACKAGING SPECIFICATIONS** Taping Specification for Radial Lead Type

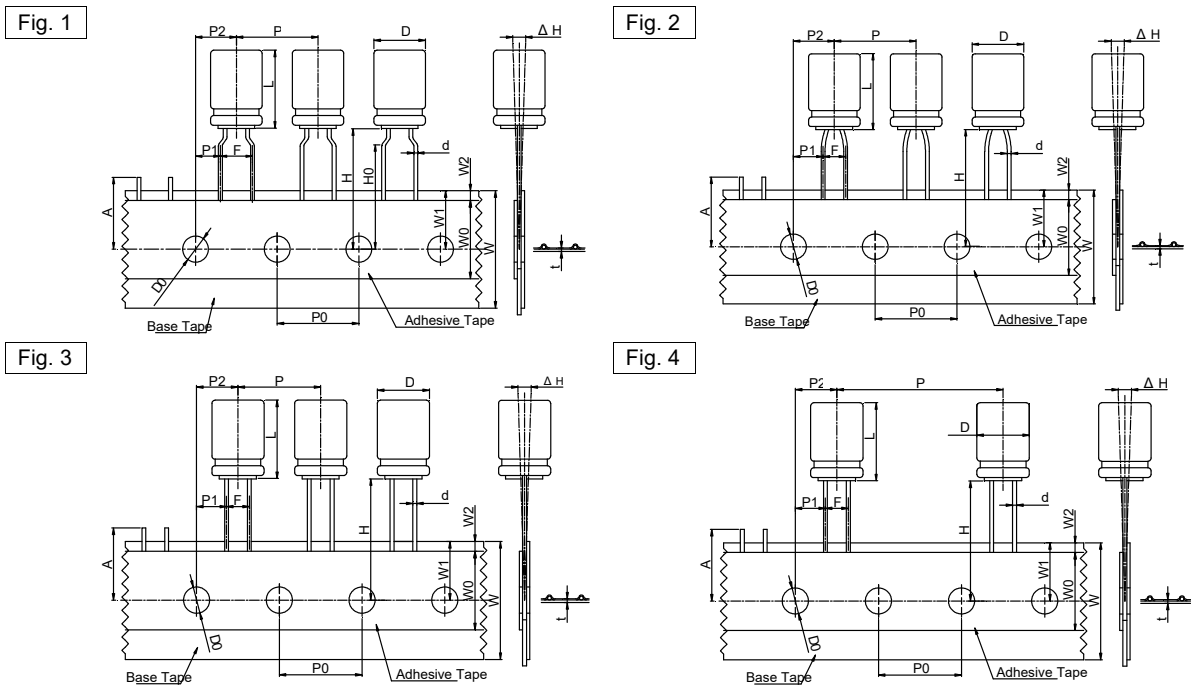

Packing	TA, TR (Fig. 1)								SA, SR (Fig. 2, 3, 4)											
	L ≤ 7mm				L ≥ 7mm				L ≤ 7mm					L ≥ 7mm						
Symbol	3	4	5	6.3	8	5	6.3	8	3	4	5	6.3	8	5	6.3	8	Tol.	10	13	Tol.
d	0.4	0.45	0.5	0.5	0.5	0.5	0.5	0.6	0.4	0.45	0.45	0.45	0.45	0.5	0.5	0.6	± 0.05	0.6	0.6	± 0.05
F	5.0	5.0	5.0	5.0	5.0	5.0	5.0	5.0	2.5	2.5	2.5	2.5	3.5	2.5	2.5	3.5	-0.2/+0.8	5.0	5.0	-0.2/+0.8
P	12.7	12.7	12.7	12.7	12.7	12.7	12.7	12.7	12.7	12.7	12.7	12.7	12.7	12.7	12.7	12.7	± 1.0	12.7	25.4	± 1.0
P0	12.7	12.7	12.7	12.7	12.7	12.7	12.7	12.7	12.7	12.7	12.7	12.7	12.7	12.7	12.7	12.7	± 0.2	12.7	12.7	± 0.30
P2	6.35	6.35	6.35	6.35	6.35	6.35	6.35	6.35	6.35	6.35	6.35	6.35	6.35	6.35	6.35	6.35	± 1.0	6.35	6.35	± 1.3
P1	3.85	3.85	3.85	3.85	3.85	3.85	3.85	3.85	5.1	5.1	5.1	5.1	4.6	5.1	4.6	± 0.5	3.85	3.85	± 0.7	
H	17.5	17.5	17.5	17.5	17.5	18.5	18.5	20.0	17.5	17.5	17.5	17.5	17.5	18.5	18.5	18.5	± 0.75	18.5	18.5	± 0.75
H0	16.0	16.0	16.0	16.0	16.0	16.0	16.0	16.0	--	--	--	--	--	--	--	± 0.5	--	--	± 0.5	
W	18.0	18.0	18.0	18.0	18.0	18.0	18.0	18.0	18.0	18.0	18.0	18.0	18.0	18.0	18.0	18.0	± 0.5	18.0	18.0	± 0.5
W0	12.0	12.0	12.0	12.0	12.0	12.0	12.0	12.0	12.0	12.0	12.0	12.0	12.0	12.0	12.0	12.0	Min	12.0	12.0	Min.
W1	9.0	9.0	9.0	9.0	9.0	9.0	9.0	9.0	9.0	9.0	9.0	9.0	9.0	9.0	9.0	9.0	± 0.5	9.0	9.0	± 0.5
W2	1.5	1.5	1.5	1.5	1.5	1.5	1.5	1.5	1.5	1.5	1.5	1.5	1.5	1.5	1.5	1.5	Max.	1.5	1.5	Max.
D0	4.0	4.0	4.0	4.0	4.0	4.0	4.0	4.0	4.0	4.0	4.0	4.0	4.0	4.0	4.0	4.0	± 0.2	4.0	4.0	± 0.2
t	0.7	0.7	0.7	0.7	0.7	0.7	0.7	0.7	0.7	0.7	0.7	0.7	0.7	0.7	0.7	0.7	± 0.2	0.7	0.7	± 0.2
Δ H	0	0	0	0	0	0	0	0	0	0	0	0	0	0	0	0	± 1.0	0	0	± 1.0
ε	1.0	1.0	1.0	1.0	1.0	1.0	1.0	1.0	1.0	1.0	1.0	1.0	1.0	1.0	1.0	1.0	Max.	1.0	1.0	Max.
A	11	11	11	11	11	11	11	11	11	11	11	11	11	11	11	11	Max.	11	11	Max.
Fig. No.	1	1	1	1	1	1	1	1	2	2	2	3	3	2	3	3		3	3,4	

### RADIAL FORMING

Lead Forming & Cutting Specifications for Radial Type (Unit: mm)

Forming Method	Code	Shape	Dimensions																																																											
Forming Cut (4 ~ 8 )	FC		<table border="1"> <thead> <tr> <th>D x L</th> <th>d</th> <th>F</th> <th>F'</th> <th>H</th> </tr> </thead> <tbody> <tr><td>3 x 5</td><td>0.40</td><td>1.0</td><td>5.0</td><td>5.0</td></tr> <tr><td>4 x 5</td><td>0.45</td><td>1.5</td><td>5.0</td><td>5.0</td></tr> <tr><td>5 x 5</td><td>0.45</td><td>2.0</td><td>5.0</td><td>5.0</td></tr> <tr><td>6.3 ~ 8 x 5</td><td>0.45</td><td>2.5</td><td>5.0</td><td>5.0</td></tr> <tr><td>4 x 7</td><td>0.45</td><td>1.5</td><td>5.0</td><td>5.0</td></tr> <tr><td>5 x 7 ~ 11</td><td>0.5</td><td>2.0</td><td>5.0</td><td>5.0</td></tr> <tr><td>6 x 7 ~ 15</td><td>0.5</td><td>2.5</td><td>5.0</td><td>5.0</td></tr> <tr><td>8 x 7 ~ 9</td><td>0.5</td><td>3.5</td><td>5.0</td><td>5.0</td></tr> <tr><td>8 x 11.5 ~ 20</td><td>0.6</td><td>3.5</td><td>5.0</td><td>5.0</td></tr> </tbody> </table>	D x L	d	F	F'	H	3 x 5	0.40	1.0	5.0	5.0	4 x 5	0.45	1.5	5.0	5.0	5 x 5	0.45	2.0	5.0	5.0	6.3 ~ 8 x 5	0.45	2.5	5.0	5.0	4 x 7	0.45	1.5	5.0	5.0	5 x 7 ~ 11	0.5	2.0	5.0	5.0	6 x 7 ~ 15	0.5	2.5	5.0	5.0	8 x 7 ~ 9	0.5	3.5	5.0	5.0	8 x 11.5 ~ 20	0.6	3.5	5.0	5.0									
			D x L	d	F	F'	H																																																							
			3 x 5	0.40	1.0	5.0	5.0																																																							
			4 x 5	0.45	1.5	5.0	5.0																																																							
			5 x 5	0.45	2.0	5.0	5.0																																																							
			6.3 ~ 8 x 5	0.45	2.5	5.0	5.0																																																							
			4 x 7	0.45	1.5	5.0	5.0																																																							
			5 x 7 ~ 11	0.5	2.0	5.0	5.0																																																							
			6 x 7 ~ 15	0.5	2.5	5.0	5.0																																																							
			8 x 7 ~ 9	0.5	3.5	5.0	5.0																																																							
8 x 11.5 ~ 20	0.6	3.5	5.0	5.0																																																										
Cut (3 ~ 25 )	CC		<table border="1"> <tbody> <tr><td>10</td><td>0.6</td><td>5.0</td><td>-</td><td>4.5</td></tr> <tr><td>12.5</td><td>0.6</td><td>5.0</td><td>-</td><td>4.5</td></tr> <tr><td>16</td><td>0.8</td><td>7.5</td><td>-</td><td>4.5</td></tr> <tr><td>18</td><td>0.8</td><td>7.5</td><td>-</td><td>4.5</td></tr> <tr><td>22</td><td>1.0</td><td>10.0</td><td>-</td><td>4.5</td></tr> <tr><td>25</td><td>1.0</td><td>12.5</td><td>-</td><td>4.5</td></tr> </tbody> </table>	10	0.6	5.0	-	4.5	12.5	0.6	5.0	-	4.5	16	0.8	7.5	-	4.5	18	0.8	7.5	-	4.5	22	1.0	10.0	-	4.5	25	1.0	12.5	-	4.5																													
			10	0.6	5.0	-	4.5																																																							
			12.5	0.6	5.0	-	4.5																																																							
			16	0.8	7.5	-	4.5																																																							
			18	0.8	7.5	-	4.5																																																							
			22	1.0	10.0	-	4.5																																																							
			25	1.0	12.5	-	4.5																																																							
			Snap-in Forming Cut (4 ~ 8 )	SF		<table border="1"> <thead> <tr> <th>D</th> <th>d</th> <th>H1</th> <th>H2</th> <th>H3</th> <th>F</th> <th>P</th> <th>E</th> </tr> </thead> <tbody> <tr><td>4 ~ 8 x 5</td><td>0.45</td><td>5.0</td><td>2.8</td><td>2.5</td><td>5.0</td><td>1.1</td><td>1.1</td></tr> <tr><td>4 x 7</td><td>0.45</td><td>5.0</td><td>2.8</td><td>2.5</td><td>5.0</td><td>1.1</td><td>1.1</td></tr> <tr><td>5 x 7 ~ 11</td><td>0.5</td><td>5.0</td><td>2.8</td><td>2.5</td><td>5.0</td><td>1.1</td><td>1.1</td></tr> <tr><td>6 x 7 ~ 15</td><td>0.5</td><td>5.0</td><td>2.8</td><td>2.5</td><td>5.0</td><td>1.1</td><td>1.1</td></tr> <tr><td>8 x 7 ~ 9</td><td>0.5</td><td>5.0</td><td>2.8</td><td>2.5</td><td>5.0</td><td>1.1</td><td>1.1</td></tr> <tr><td>8 x 11.5 ~ 20</td><td>0.6</td><td>5.0</td><td>2.8</td><td>2.5</td><td>5.0</td><td>1.1</td><td>1.1</td></tr> </tbody> </table>	D	d	H1	H2	H3	F	P	E	4 ~ 8 x 5	0.45	5.0	2.8	2.5	5.0	1.1	1.1	4 x 7	0.45	5.0	2.8	2.5	5.0	1.1	1.1	5 x 7 ~ 11	0.5	5.0	2.8	2.5	5.0	1.1	1.1	6 x 7 ~ 15	0.5	5.0	2.8	2.5	5.0	1.1	1.1	8 x 7 ~ 9	0.5	5.0	2.8	2.5	5.0	1.1	1.1	8 x 11.5 ~ 20	0.6	5.0	2.8	2.5	5.0	1.1	1.1
						D	d	H1	H2	H3	F	P	E																																																	
						4 ~ 8 x 5	0.45	5.0	2.8	2.5	5.0	1.1	1.1																																																	
4 x 7	0.45	5.0				2.8	2.5	5.0	1.1	1.1																																																				
5 x 7 ~ 11	0.5	5.0				2.8	2.5	5.0	1.1	1.1																																																				
6 x 7 ~ 15	0.5	5.0				2.8	2.5	5.0	1.1	1.1																																																				
8 x 7 ~ 9	0.5	5.0				2.8	2.5	5.0	1.1	1.1																																																				
8 x 11.5 ~ 20	0.6	5.0				2.8	2.5	5.0	1.1	1.1																																																				
Snap-in Forming Cut (10 ~ 25 )	SC					<table border="1"> <tbody> <tr><td>10</td><td>0.6</td><td>4.5</td><td>2.5</td><td>-</td><td>5.0</td><td>1.2</td><td>1.1</td></tr> <tr><td>12.5</td><td>0.6</td><td>4.5</td><td>2.5</td><td>-</td><td>5.0</td><td>1.2</td><td>1.1</td></tr> <tr><td>16</td><td>0.8</td><td>4.5</td><td>2.5</td><td>-</td><td>7.5</td><td>1.2</td><td>1.1</td></tr> <tr><td>18</td><td>0.8</td><td>4.5</td><td>2.5</td><td>-</td><td>7.5</td><td>1.2</td><td>1.1</td></tr> <tr><td>22</td><td>1.0</td><td>4.5</td><td>2.5</td><td>-</td><td>10.0</td><td>1.2</td><td>1.3</td></tr> <tr><td>25</td><td>1.0</td><td>4.5</td><td>2.5</td><td>-</td><td>12.5</td><td>1.2</td><td>1.3</td></tr> </tbody> </table>	10	0.6	4.5	2.5	-	5.0	1.2	1.1	12.5	0.6	4.5	2.5	-	5.0	1.2	1.1	16	0.8	4.5	2.5	-	7.5	1.2	1.1	18	0.8	4.5	2.5	-	7.5	1.2	1.1	22	1.0	4.5	2.5	-	10.0	1.2	1.3	25	1.0	4.5	2.5	-	12.5	1.2	1.3								
						10	0.6	4.5	2.5	-	5.0	1.2	1.1																																																	
			12.5	0.6	4.5	2.5	-	5.0	1.2	1.1																																																				
			16	0.8	4.5	2.5	-	7.5	1.2	1.1																																																				
			18	0.8	4.5	2.5	-	7.5	1.2	1.1																																																				
			22	1.0	4.5	2.5	-	10.0	1.2	1.3																																																				
25	1.0	4.5	2.5	-	12.5	1.2	1.3																																																							
Bending Cut (5 ~ 25 )	BC		<table border="1"> <thead> <tr> <th>D x L</th> <th>d</th> <th>F±0.5</th> </tr> </thead> <tbody> <tr><td>5 X 11</td><td>0.5</td><td>2.0</td></tr> <tr><td>6.3 X 11 ~ 15</td><td>0.5</td><td>2.5</td></tr> <tr><td>8 X 11.5 ~ 20</td><td>0.6</td><td>3.5</td></tr> </tbody> </table>	D x L	d	F±0.5	5 X 11	0.5	2.0	6.3 X 11 ~ 15	0.5	2.5	8 X 11.5 ~ 20	0.6	3.5																																															
			D x L	d	F±0.5																																																									
			5 X 11	0.5	2.0																																																									
			6.3 X 11 ~ 15	0.5	2.5																																																									
8 X 11.5 ~ 20	0.6	3.5																																																												
(10 ~ 25 )	SD		<table border="1"> <tbody> <tr><td>10</td><td>0.6</td><td>5.0</td></tr> <tr><td>12.5</td><td>0.6</td><td>5.0</td></tr> <tr><td>16</td><td>0.8</td><td>7.5</td></tr> <tr><td>18</td><td>0.8</td><td>7.5</td></tr> <tr><td>22</td><td>1.0</td><td>10.0</td></tr> <tr><td>25</td><td>1.0</td><td>12.5</td></tr> </tbody> </table>	10	0.6	5.0	12.5	0.6	5.0	16	0.8	7.5	18	0.8	7.5	22	1.0	10.0	25	1.0	12.5																																									
			10	0.6	5.0																																																									
			12.5	0.6	5.0																																																									
			16	0.8	7.5																																																									
			18	0.8	7.5																																																									
22	1.0	10.0																																																												
25	1.0	12.5																																																												

Ammo pack box. (SA, TA) Reel pack box. (SR, TR)  
10 Boxes per carton

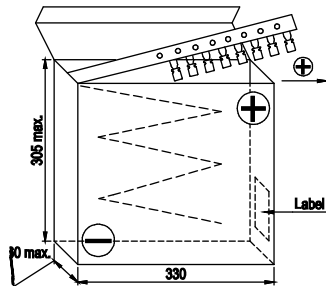

Packaging Quantity

D	3	4	5	6.3	8	10	13
TA, SA	3000	2000	2000	2000	1000	500	250
TR, SR	3000	1500	1200	1000	800	500	500

NOTES:

- The above quantities are typical. Quantities may vary.
- The component will be oriented on the tape so that the positive lead is leading or the negative lead is leading, depending on the customer's request